

# A chip for catching, separating, and transporting bio-particles with dielectrophoresis

Jung-Tang Huang · Guo-Chen Wang ·  
Kuang-Ming Tseng · Shiuh-Bin Fang

Received: 24 March 2008 / Accepted: 31 July 2008 / Published online: 22 August 2008  
© Society for Industrial Microbiology 2008

**Abstract** This study aims at developing a 3D device for catching, separating, and transporting bio-particles based on dielectrophoresis (DEP). Target particles can be simultaneously caught and transported using the negative DEP method. In non-uniform electric fields, the levitation height or complex permittivity of certain particle may be different from that of another and this property can facilitate separation of particles. We have designed and constructed a 3D device consisting of two layers of electrodes separated by a channel formed by 50  $\mu\text{m}$  thick photoresist. The electrodes can operate effectively with 10–15 V and 5–7 MHz to catch all particles in the channel, and can move particles after switching the electric field to 5–15 V and 500–1,000 KHz. Hence, particles experienced coupling force of two different directional twDEP forces, and tallied with our estimation to move along the coupling direction.

**Keywords** Biochip · Dielectrophoresis · Separating · Catching · Transporting

## Introduction

There is a great need for miniature devices and systems to provide precise and high-throughput analysis and characterization of bioparticles such as cells and micro-

organisms [1]. By integrating several critical miniature components on a single chip, a biochip system can perform functions such as preparation, transporting, reaction, mixing, separation, and detection for sample analysis and characterization. Basically, dielectrophoresis force is one of important methods to separate and transport bioparticles in the biochip other than micro pumping [2–10]. However, there are still several drawbacks of the traditional dielectrophoresis (DEP) method to satisfactorily separate bioparticles. For example, it is difficult to use DEP forces for separation when two different particles encounter negative DEP simultaneously. Therefore, we strive to develop a 3D DEP device to entirely separate and then transport bioparticles along the direction for collection.

Characterization of a particle's property is necessary because a DEP force is mainly constituted by particle size, permittivity, and frequency. In most applications, permittivity and size cannot be tuned artificially and thus a DEP force mainly varies with frequency. Currently, ROT (Electrorotation) measurement and Levitator measurement are the main methods to calculate the permittivity of a particle [3]. At first, we used ROT to measure the factor of a particle and designed a structure of 3D electrodes, followed by use of CFD (Computational Fluid Dynamics) software to predict the dynamic behavior of the particle. After analysis, the structure can be used to generate two coupling DEP force, to fabricate the chip, and to implement experiments for evaluating the functions of the chip.

## Theory

The time-averaged DEP force exerting on a particle arises from the interaction of the induced dipole moment with the applied field phasor. This is summarized for a particle of

J.-T. Huang (✉) · G.-C. Wang · K.-M. Tseng  
Institute of Mechatronics Engineering,  
National Taipei University of Technology,  
1, Sec. 3, Zhong Xiao E. Rd., Taipei 106, Taiwan  
e-mail: jthuang@ntut.edu.tw

S.-B. Fang  
Taiwan Adventist Hospital, Taipei, Taiwan

radius  $r$  suspended in a medium of permittivity  $\epsilon_m$  by the following equations [2]:

$$F = F_{\text{DEP}} + F_{\text{twDEP}} \quad (1)$$

$$F_{\text{DEP}} = 2\pi\epsilon_m r^3 \text{Re}(f_{\text{cm}}) \nabla E^2 \quad (2)$$

$$F_{\text{twDEP}} = 2\pi\epsilon_m r^3 \text{Im}(f_{\text{cm}}) \sum E^2 \nabla \phi \quad (3)$$

$\nabla E^2$  is the gradient of the square of the field  $E$ , and  $\sum E^2 \nabla \phi$  depicts a summation involving the magnitude and phase  $\phi$  of each field component. The polarizability factor  $f_{\text{cm}}$  determines the magnitude of the induced dipole moment and is a function of the frequency of the applied field and the conductivity and permittivity of the particle and its suspending medium.  $\text{Re}(f_{\text{cm}})$  and  $\text{Im}(f_{\text{cm}})$  relate to the real (in-phase) and imaginary (out-of-phase) components of this dipole moment, respectively.

For the DEP case, the electrodes are operated with the two phases of  $0^\circ$  and  $180^\circ$ . In this case, the factor  $\sum E^2 \nabla \phi$  in Eq. (3) is zero, therefore,  $F_{\text{twDEP}}$  becomes zero. The resulting force which either levitates the particles or attracts them to the electrodes depends on  $\text{Re}(f_{\text{cm}})$ . If  $\text{Re}(f_{\text{cm}})$  is positive, particles will be attracted by the electrodes. On the contrary, particles will be levitated.

When particles are levitated, particles encounter three dominant forces: a gravitational force  $F_g$ , negative DEP force  $F_{\text{DEP}}$ , and twDEP force  $F_{\text{twDEP}}$ . For a spherical particle of radius  $r$  of mass density  $\rho_p$ , it may suspend in a medium of mass density  $\rho_m$ . The gravitation force is given by Eq. (4)

$$F_g = 4/3\pi r^3 (\rho_m - \rho_p) g \quad (4)$$

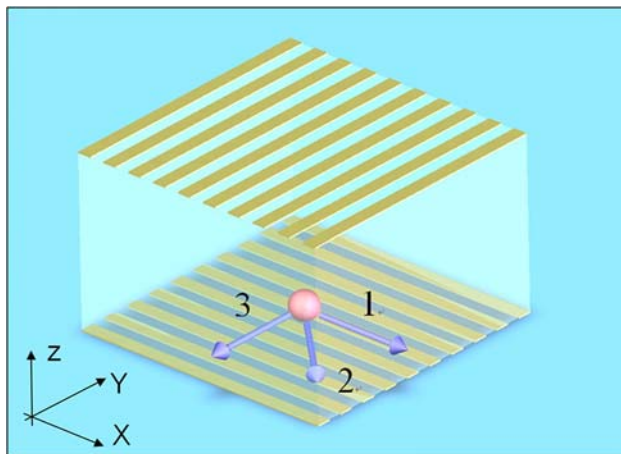
$g$  is the gravitational acceleration. When particles are levitated to a stable position where the opposing gravitational and DEP forces balance to give

$$F_g + F_{\text{DEP}} = 0 \quad (5)$$

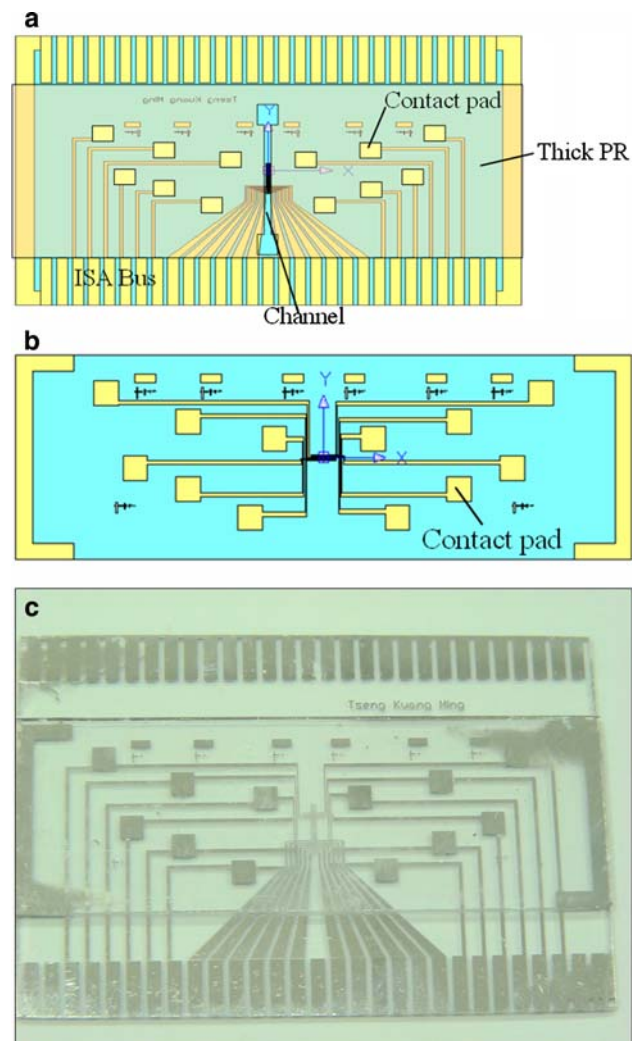
From the above description, particles with different dielectric properties can be levitated to different heights in the channel.

### Structure of biochip

This research used 3D electrodes to achieve the goal which is to travel all particles in channel. Figure 1 shows the

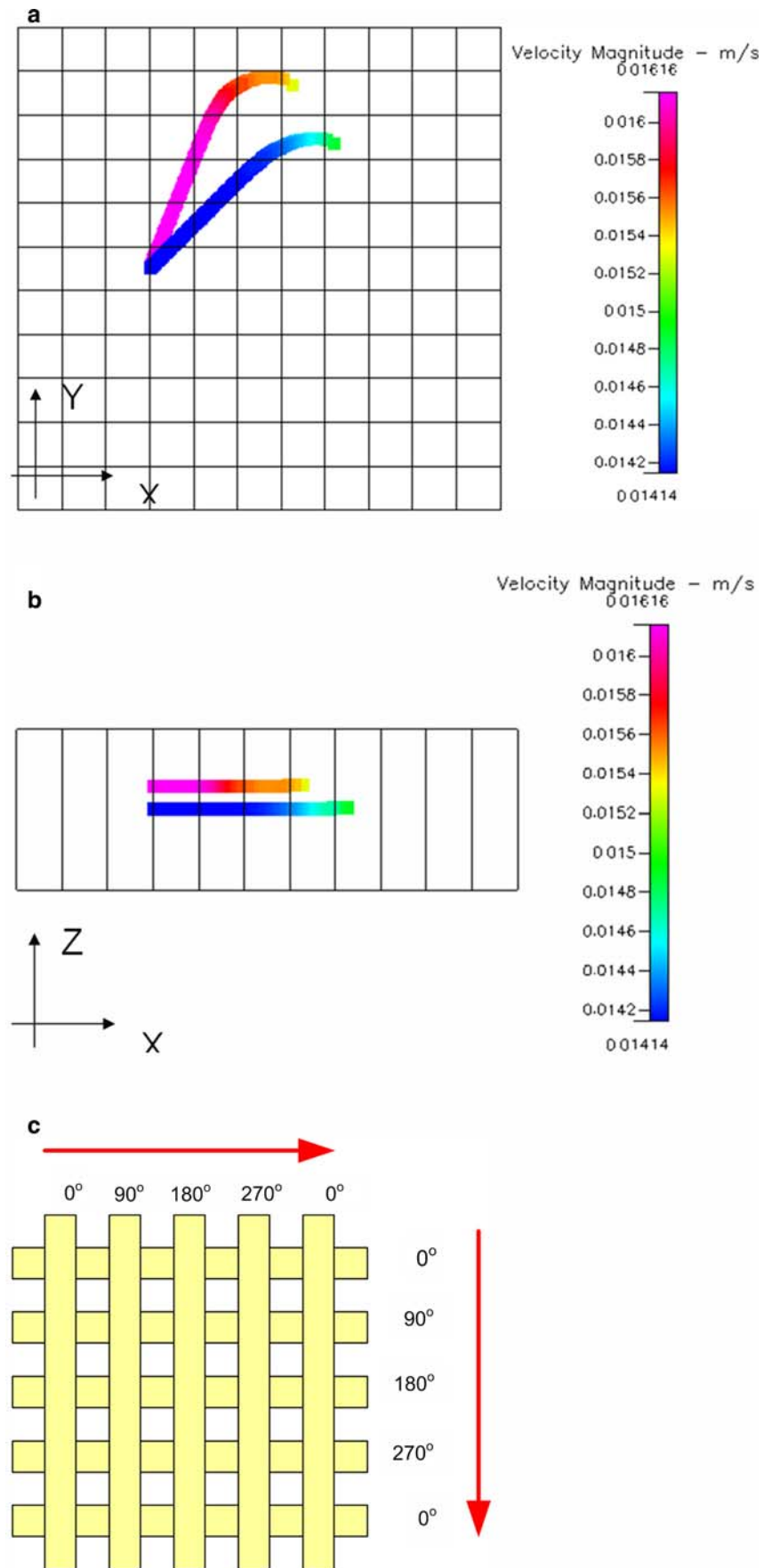


**Fig. 1** The 3D structure of electrodes. The upside electrodes are perpendicular to underside electrodes. Electrodes are energized with the four phases ( $0^\circ$ ,  $90^\circ$ ,  $180^\circ$ , and  $270^\circ$ ). After encountering the twDEP provided by the upside electrodes particles move along the *arrowhead 1*. In the same situation according to the theory, particles experience twDEP provided by the underside electrodes they move along the *arrowhead 3*. Particles simultaneously encounter the coupling force of two twDEP forces in different directions generated by upside electrodes and underside electrodes, and accordingly go along the *arrowhead 2*



**Fig. 2** **a** The underside substrate with electrode pattern composed of 12 fingers and 12 contact pads for connecting signal to the electrodes on the upside substrate; the fluid channel was patterned on the  $50 \mu\text{m}$  thick PR. **b** The electrode pattern on the upside substrate. **c** The picture of the assembled biochip through bonding the aligned contact pads with silver conductive glue

**Fig. 3** The simulations of separating particles: **a** *X, Y* plane view of simulation, two particles with different densities were separated toward different directions. **b** *X, Z* plane view of simulation, the two particles were separated at the different levitation height. **c** The initial phases set on the electrodes



structure of 3D electrodes. There are three components in this device, one is the upside electrode substrate, another is the underside electrode substrate and the other is the channel between the two different plates. The two kinds of electrodes are perpendicular to each other.

For the underside substrate, a traveling field is generated when the electrodes are sequentially energized with sinusoidal voltages of the same frequency, and with a phase difference of  $90^\circ$  between consecutive electrodes. In this case, the force consists of  $F_{\text{DEP}}$  and  $F_{\text{twDEP}}$ , particles are levitated above the electrodes by a negative DEP force and traveled by the traveling wave dielectrophoresis (twDEP). The direction of induced twDEP motion is based on the magnitude of  $\sum E^2 \nabla \phi$  and  $\text{Im}(f_{\text{cm}})$ . The direction of propagation is toward the smaller phase regions. Reversing this quadrature phase sequence causes the direction of wave propagation to reverse. The traveling wave has a wavelength  $\lambda$  equal to the distance between every fourth electrodes. For DEP, the electrodes are connected alternately to two sinusoidal voltages of the same frequency with phases of  $0^\circ$  and  $180^\circ$ . This creates a stationary ac field.

After encountering the twDEP provided by the upside electrodes particles move along the arrowhead 1 (Fig. 1). In the same situation according to the theory, particles experiencing twDEP provided by the underside electrodes will move along the arrowhead 3. Particles simultaneously encountering the coupling force of two twDEP forces in different directions generated by upside and underside electrodes will accordingly go along the arrowhead 2.

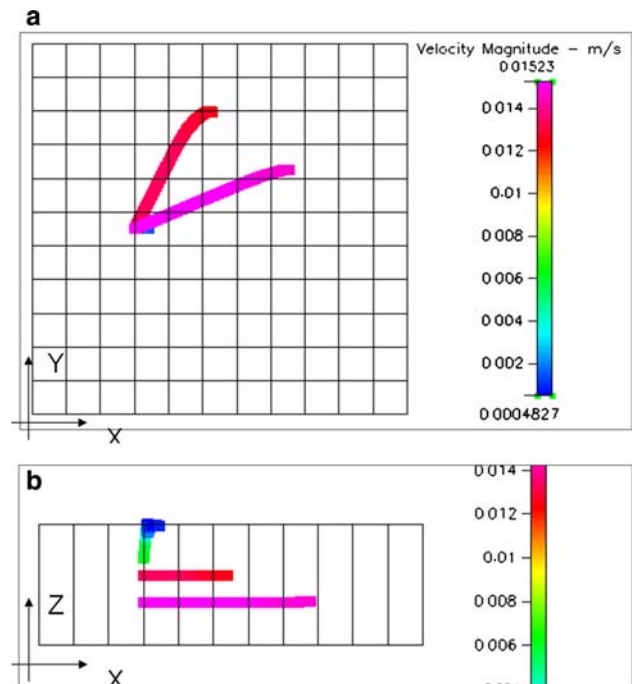
When particles are close to the underside electrodes, they will be moved by underside electrodes. By means of the height of particles, they will run toward different directions. So we can separate two more kinds of particles experiencing negative DEP. By this new separation method, many varied particles can be separated and traveled fast and widely at the same time.

Glass was used as substrate in order to observe particles easily in our experiment. The electrodes were constructed on the glass. The underside and upside electrodes were fabricated by a thermal evaporator to deposit a layer of aluminum and then by wet etchant to etch the Al to construct the electrode pattern. The fluid channel was patterned on the thick photoresist (T151 N) deposited on the underside electrodes. Figure 2a and b shows the structures of underside and upside electrodes and Fig. 2c shows the picture of the assembled chip. Considering the experimental stability and accuracy, AC electric field should precisely transmit to electrodes. Therefore we adopted ISA (Industry Standard Architecture) Bus slot to connect the assembled chip. The width  $d$  of each electrode is  $30 \mu\text{m}$ , while the space between electrodes is  $10 \mu\text{m}$ . The gap between the upside and underside electrodes is

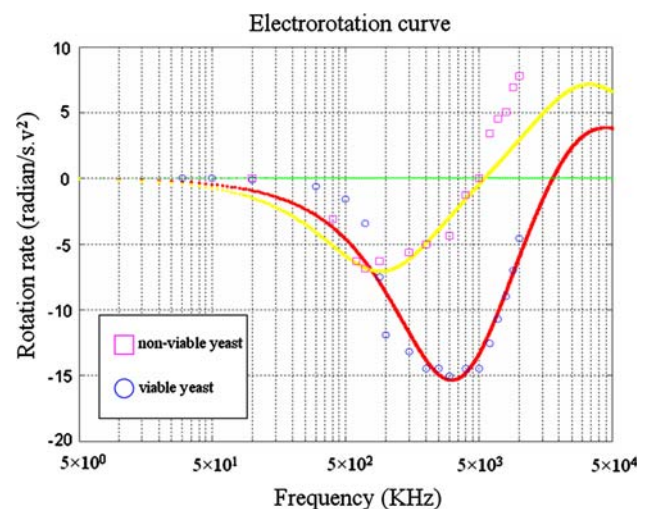
$50 \mu\text{m}$ , which can guarantee the  $\nabla E^2$  and  $\sum E^2 \nabla \phi$  above the electrodes have sufficient intensity to actuate the bio-particles [2].

### Simulation

In this section, we employed CFD software (CFDRC) to predict the dynamic behaviors of particles. Assume that the



**Fig. 4** The simulations of separating multiple particles: the first two experiencing different negative DEP and twDEP were separated and moved to different directions, while the third one was attracted to the electrodes. **a**, X, Y plane view, **b** X, Z plane view



**Fig. 5** ROT curves for viable and non-viable yeast with medium conductivity of  $0.1 \text{ S/m}$  and the signal frequency being in the range of  $10\text{--}10,000 \text{ KHz}$

particle was polystyrene bead that the dielectric coefficient of the particle was  $2.5\epsilon_0$ , and the dielectric coefficient of solution was  $78\epsilon_0$ . The conductivity of polystyrene was set  $1 \times 10^{-12}$  S/m, and the conductivity of solution was 0.011 S/m. The applied signal is 1 MHz and 10 V<sub>p-p</sub>. Note that although yeast cells were target particles for our latter experiments, the polystyrene beads were used instead due to limitation of setting properties of real bioparticles such as yeast cell in the software.

For the simulation of separating two particles with different density, one particle was assumed 1,040 Kg/m<sup>3</sup>, and the other was 800 Kg/m<sup>3</sup>. The particles were affected by negative DEP and twDEP in this situation. The two different particles were set at the same position of X, Y plane, but at different heights. Figure 3a shows that the initial heights of two particles were different due to different gravitation force as described in Eq. (5). The initial phase of signal applied to the electrodes is shown as Fig. 3c. Figure 3b shows that the two particles were separated at two different levitation heights in the solution. Hence, two particles with the same dielectric properties and different densities could be separated effectively in our method.

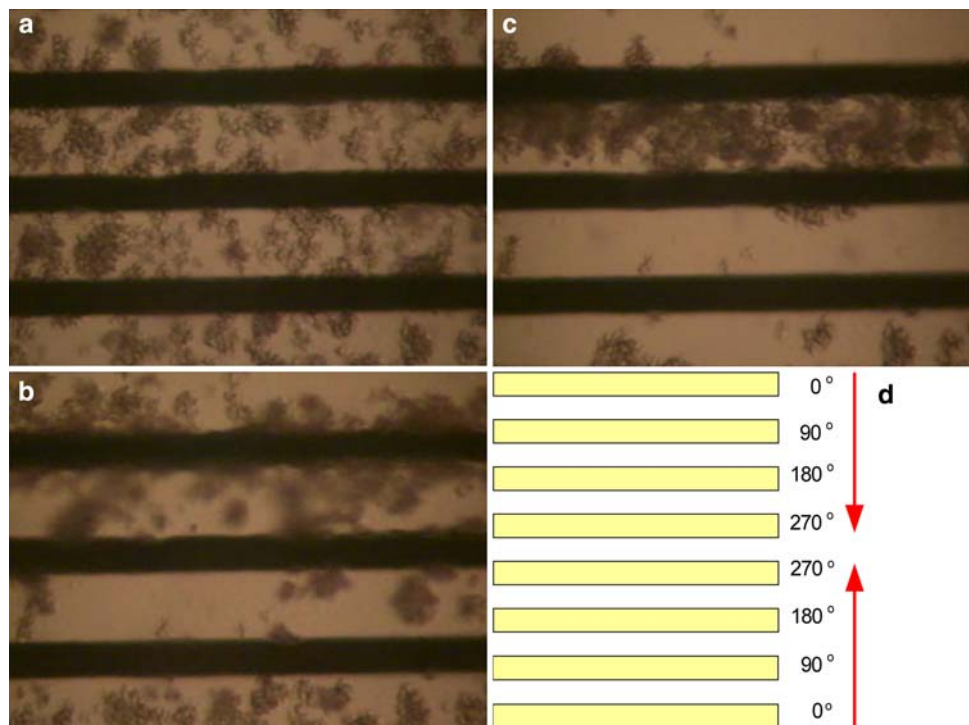
For the case of separating three particles: the first two with the same density of 1,040 Kg/m<sup>3</sup> but different dielectric coefficient, one was  $2.5\epsilon_0$ , and the other was  $3.5\epsilon_0$ , while the third one experiencing positive DEP due to its much higher internal conductivity. The three different particles were set in the same position of X, Y plane, but at different heights due to unbalance between DEP force and gravitation force. Figure 4a shows that the

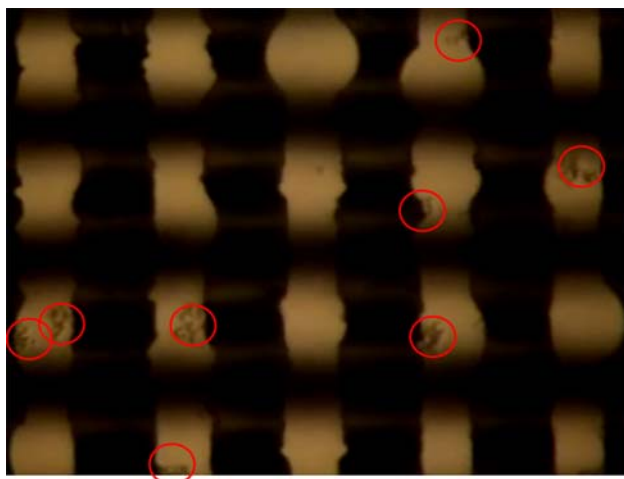
initial heights of the first two particles experiencing different negative DEP and twDEP were different, and then separated and moved to different directions. Figure 4b shows that the first two particles were separated at two different levitation heights in the solution, and the third particle experiencing positive DEP was attracted to the edge of the electrode.

### Experiment

The feasibility of the separation mechanism in the DEP chip with 3D electrode array was proved using populations of viable and non-viable yeast cells. 100 mg of yeast, 100 mg of sugar and 2 ml DI water were incubated in a test tube at 37 °C for 2 h. Next, the cell culture was divided into two with one population being boiled for several minutes in 5 ml boiling DI water (dead cells). ROT experiments for both populations were implemented to obtain the ROT curves [11]. The conductivity of the medium was 0.1 S/m after blending with 1 M KCL solution. Afterward, yeast cells were added into the medium and the mixture was deposited into the channel of the experimental chip. We conducted three experiments: yeast cells were caught by electrodes; yeast cells were moved by one-side electrodes, and yeast cells were separated by both underside and upside electrodes. In the experiment, we observed motion of yeast cells in the channel when the drive signal was increased from 0 to 20 V peak to peak gradually with the signal frequency being in the range of 10–10,000 kHz.

**Fig. 6** Distributed yeast cells were traveled and collected into a small region in the channel following the signal phases applied to the planar electrodes, when the medium conductivity was 0.1 S/m and 5 V<sub>p-p</sub> at 1 MHz was employed





**Fig. 7** Non-viable yeast cells were caught by 3D electrodes in the solution with conductivity of 0.1 S/m by applying 5 V<sub>P-P</sub> at 7 MHz. The circle points the locations of yeast cells

## Results and discussion

The ROT curves for viable and non-viable yeast cells were curve-fitted (Fig. 5) to approximate to the measured results based on experiment conducted with medium conductivity of 0.1 S/m and the signal frequency being in the range of 10–10,000 kHz. The results indicate the viable and non-viable yeast cells will experience negative DEP forces if the signal frequency band is less than 5 MHz. Around 1 MHz, the viable yeast cells will experience much

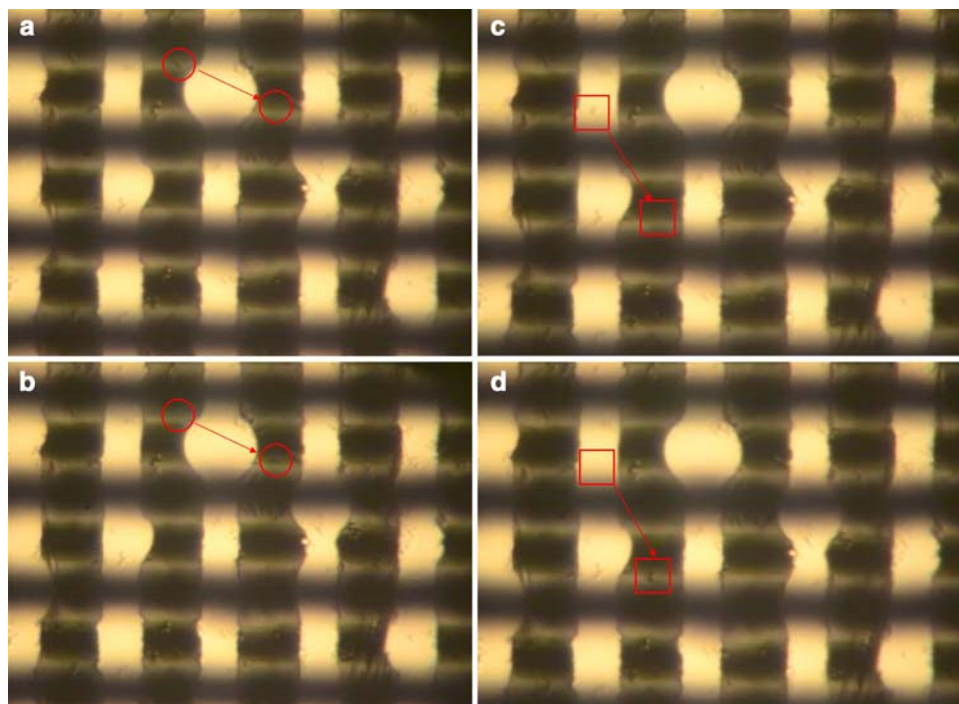
stronger negative DEP forces than non-viable yeast cells do.

In the transporting experiment (Fig. 6), yeast cells in the channel experiencing negative DEP and twDEP forces were collected into a small region by addressing the parallel planer electrodes with signal phase as shown in Fig. 6d, when medium conductivity was 0.1 S/m and signal of 5 V<sub>P-P</sub> at 1 MHz. was applied.

In the catching experiment, non-viable yeast cells in the channel were entirely trapped by the 3D electrodes (Fig. 7) when the signal frequency was larger than 5 MHz, voltage 5 V<sub>P-P</sub> and medium conductivity 0.1 S/m.

Figure 8 showed the bidirectional separation processes for viable and non-viable yeast cells in a DEP chip. The mixture of viable and non-viable yeast cells was injected into the microchannel; The yeast cells in the channel were levitated at the different heights by underside electrodes, non-viable yeast cells experiencing weaker negative DEP and twDEP forces moved toward the eastern regions (Fig. 8a, b) and viable yeast cells experiencing stronger negative DEP and twDEP forces moved toward the southern regions (Fig. 8c, d). Note that the signals applied to the upside and underside electrodes could be different, indicating the proposed biochip has powerful capability of manipulating a variety of particles simultaneously. However, the size dispersion is intrinsically related to any biological materials and should be considered before using our method. The reason is the DEP force is proportional to the bioparticle volume as indicated in Eqs. (2) and (3) and it may influence the transporting velocity.

**Fig. 8** The bidirectional separation processes for viable and non-viable yeast cells in a DEP chip. **a–b** The circle points the location of the non-viable yeast cells, **c–d** the square points the location of the viable yeast cells; and the arrowhead points their moving paths



This paper proposed a multidirectional separation method in a DEP chip with 3D electrode array, which also functions as microfluidic channels. The chip utilizes TW-DEP and DEP to affect biological cells, using an orthogonal set of planar electrodes, located above and below the channel walls. These electrodes serve several functions. The first function is to generate positive and negative dielectrophoretic force, catching two populations of cells in different locations. The second function is to produce a transporting velocity by employing coupling twDEP force to transport and separate particles toward different directions at the same time. This method has been successfully tested using the mixture of viable and non-viable yeast cells, which should provide a great potential for separation of different bio-particles in biological and medical fields.

**Acknowledgments** This research is partly supported by Taiwan National Science Council and National Health Research Institutes, NHRI-EX96-9628SI. We would like to thank for all the fund sponsors.

## References

- Doh I, Cho YH (2005) A continuous cell separation chip using hydrodynamic dielectrophoresis process. *Sens Actuators A* 121: 59–65
- Pethig R, Talary MS, Lee RS (2003) Enhancing traveling-wave dielectrophoresis with signal superposition. *IEEE Eng Med Biol Mag* 22:43–50
- Markx GH, Pethig R, Rousselet J (1998) The dielectrophoretic levitation of latex beads, with reference to field-flow fractionation. *J Phys D Appl Phys Microelectromech Syst* 7:106–113
- Yang J, Huang Y, Wang X-B, Becker FF, Gascoyne PRC (1999) Cell separation on microfabricated electrodes using dielectrophoretic/gravitational field-flow fractionation. *Anal Chem* 71:911–918
- Morgan H, Izquierdo AG, Bakewell D, Green NG, Ramos A (2001) The dielectrophoretic and traveling wave forces generated by interdigitated electrode arrays: analytical solution using Fourier series. *J Phys D Appl Phys* 34:1553–1561
- Muller T, Gradl G, Howitz S, Shirley S, Schnelle T, Fuhr G (1999) A 3-D microelectrode system for handling and caging single cells and particles. *J Biosens Bioelectron* 14:247–256
- Li WH, Du H, Chen DF, Shu C (2004) Analysis of dielectrophoretic electrode arrays for nanoparticle manipulation. *J Comput Materials Sci* 30:320–325
- Kruger J, Singh K, O’Neill A, Jackson C, Morrison A, Brien PO (2002) Development of a microfluidic device of fluorescence activated cell sorting. *J Micromech Microeng* 12:486–494
- Wang X-B, Huang Y, Wang X, Becker FF, Gascoyne PRC (1997) Dielectrophoretic manipulation of cells in spiral electrodes. *Biophys J* 72:1887–1899
- Iliescu C, Yu L, Tay FEH, Chen B (2008) Bidirectional field-flow particle separation method in a dielectrophoretic chip with 3D electrodes. *Sens Actuators B* 129:491–496
- Georgieva R, Neu B, Shilov VM, Knippel E, Budde A, Latza R, Donath E, Kiesewetter H, Barmler H (1998) Low frequency electrorotation of fix red blood cells. *Biophys J* 74:2114–2120